

TMB SERIES

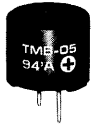

FEATURES

- Dip-solderable and washable
(See page 35 for details.)
- Compact
- Low current consumption

APPLICATIONS

microwave oven, printer, telephone, electronic cash register, timer, automobile electronics, POS system, portable battery-operated equipment, computer peripherals.

SPECIFICATIONS

Type	TMB-05	TMB-12
◆ Rated Voltage (V)	5	12
Operating Voltage (V)	4~6.5	8~16
※ Mean Current Consumption (mA)	MAX30 (TYP22)	MAX30 (TYP15)
※ Sound Output at 10cm (dB)	MIN85 (TYP87)	
※ Basic Frequency (Hz)	2,300±300	
☆ Response Time (msec)	MAX50	
Operating Temperature (°C)	-40 ~ +85	
Storage Temperature (°C)	-40 ~ +85	
Weight (g)	2	

◆ See P.6 for details
 ※ Value applying rated voltage.
 ☆ Value applying min. operating voltage

DIMENSIONS

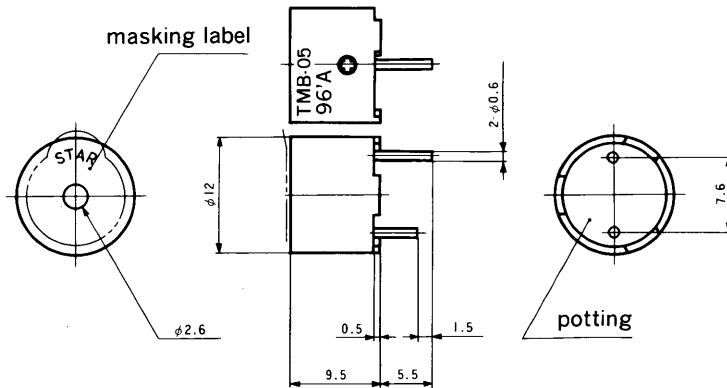

unit:mm
 housing material:PPE-M
 ※ Long pin:(+)

CHARACTERISTICS

(TMB-05)
 Sound Output vs. Voltage

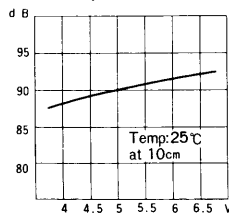

Current vs. Voltage

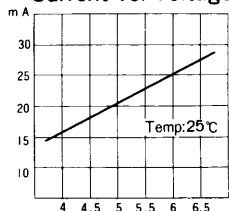

(TMB-12)
 Sound Output vs. Voltage

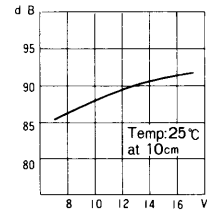

Current vs. Voltage

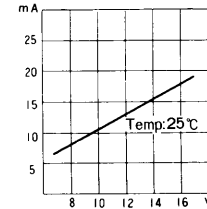

■ SOLDERING AND WASHING

1- Soldering: The sealed miniature sound transducers by Star should not be exposed to extremely high temperatures for prolonged periods of time. As excessive heat will degrade the sealing performance of the unit, soldering should be conducted as quickly as possible.

Recommended temperature and time for soldering
 250°Cwithin 5 seconds
 350°Cwithin 1.5 seconds

2- Washing:

A. Washable type transducers.

Along with other electronic components, these transducers may be washed with cleaning solvents after the soldering process. However, some types of solvents can be harmful to these devices.

B. Nonwashable type transducers.

Most cleaning solvents will be damaging to these devices, therefore wave soldering & washing should be avoided.

■ FLUX REMOVING SOLVENTS

In view of the recent requirement for total elimination of ozone-depleting chemicals, we have decided to recommend our customers to use deionized water for their cleaning process at the conditions given below, instead of CFC that was conventionally used.

[Conditions for cleaning]

Cleaning solvent.....Deionized water
 Solvent temperature..... 55±5°C
 immersion time..... 5±0.5minutes

For further details, feel free to ask us directly or any of our distributors.

■ TRIGGER CONTROL TERMINAL

For the application of the buzzer such as Type CMB and YMB that has a trigger control terminal:

This type of buzzer may be considered as an ordinary two-terminal buzzer such as Type SMB with a kind of switching circuit consisting of an NPN transistor and a resistor is added as shown in Fig. 9. The voltage input (at "High" level) applied to the control terminal marked as "(C)" will trigger the NPN transistor to activate the buzzer. And if a pulsed voltage input is applied to the terminal (C) as shown in Fig. 10, the pulsed sound output may be obtained, but in such case the pulse width must be adequate enough for the buzzer to respond to it.

In case it is unnecessary to control the activation of buzzer through (C) terminal, the buzzer may be used as an ordinary two-terminal buzzer with such (C) terminal directly connected to (+) as shown in Fig. 11.

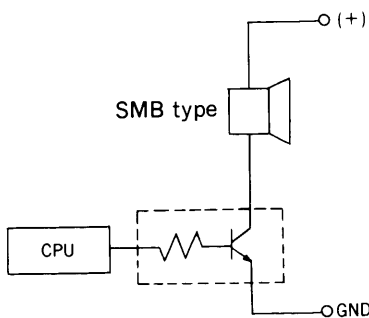

Fig.9

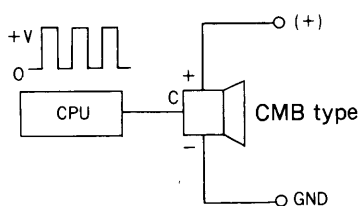

Fig.10

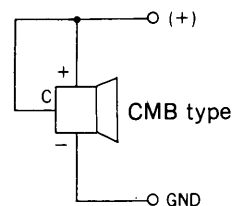

Fig.11

■ Mean Current Consumption 2

Excessive restriction in the current fed to Miniature audio transducers and Low-pitched buzzers will adversely affect the oscillation and may result in no sound generation. It is therefore required to design the circuit to supply the current sufficient for the peak current needed to generate a sound, two or three times as much as the averagedly consumed current(See Page 4.)

Miniature Audio Transducer (External drive circuitry)

Reflowable type (Note1)

Type	Model	Dimensions (mm)	Rated Voltage (V)	Operating Voltage (V)	Resonant Frequency (Hz)	Sound Output (dBA)	Frequency Band(Hz) (MIN80dBA Note3)	Average Current Consumption (mA)	Temperature Range (°C)	Weight (g)	Page
MNT	MNT-03A	9×9×4.5	3.6	~4.3	2,670	MIN85(10cm)		MAX90	-30~+70	1	7
MXT	MXT-03A	9×9×4.5	3.6	~4.3	2,670	MIN85(10cm)		MAX90	-30~+70	1	7
MUT-A	MUT-01A	11×14×3	1.5	~1.7	3,200	MIN85(10cm)		MAX65	-20~+70	1	8
	MUT-03A	11×14×3	3	~4.5	3,200	MIN87(10cm)		MAX70	-20~+70	1	8
MUT-D	MUT-01D	11×14×3	1.5	~1.7	2,670	MIN85(10cm)		MAX70	-20~+70	1	8
MUT-B	MUT-01B	13×15×2.9	1.5	~1.7	2,670	MIN85(10cm)		MAX70	-20~+70	1	9
	MUT-03B	13×15×2.9	3	~4.5	2,670	MIN87(10cm)		MAX70	-20~+70	1	9

Non-washable type

Type	Model	Dimensions (mm)	Rated Voltage (V)	Operating Voltage (V)	Resonant Frequency (Hz)	Sound Output (dBA)	Frequency Band(Hz) (MIN80dBA Note3)	Average Current Consumption (mA)	Temperature Range (°C)	Weight (g)	Page
QCL	QCL-03A	φ9×4	3.6	~4	2,670	MIN85(10cm)		MAX90	-20~+60	1	10
	QCN-03A	φ9×4	3.6	~4	2,670	MIN85(10cm)		MAX90	-20~+60	1	10
QCP	QCP-03A	φ9×4.5	3.6	~4.3	2,670	MIN85(10cm)		MAX90	-30~+60	1	10
MMX	MMX-01A	φ9×8	1.5	~2		MIN87(10cm)	2,700~3,600	MAX90	-20~+60	1	11
	MMX-01B	φ9×8	1.5	~2		MIN87(10cm)	2,700~3,600	MAX90	-20~+60	1	11
	MMX-01C	φ9.6×7.1	1.5	~2	3,100	MIN80(10cm)		MAX80	-20~+60	1	11
QEP	QEP-05A	φ12×5	5	~5	2,090	MIN82(10cm)		MAX50	-30~+60	1	12
QMB-105	QMB-105P	φ12×5.4	1.5	~2	2,048	MIN70(10cm)		MAX10	-20~+60	2	12
QMB-108	QMB-108P	φ12×7.5	1.5	~2	2,743	MIN85(10cm)		MAX70	-20~+60	2	13
QMB-111	QMB-111PN	φ12×8.5	1.5	~2	2,048	MIN80(10cm)		MAX10	-20~+60	2	13
	QMB-111GP	φ12×8.5	1.5	~2	2,048	MIN85(10cm)		MAX35	-20~+60	2	13
	QMB-111PC	φ12×8.5	5	~5	2,000	MIN85(10cm)		MAX40	-20~+60	2	13
QMB-113	QMB-113P	φ12×13	1.5	~2	2,048	MIN80(10cm)		MAX35	-20~+60	2	14
PMX-06	PMX-06B	φ12×5.8	1.5	~2	2,731	MIN83(10cm)		MAX70	-20~+60	2	14
PMX-04	PMX-04A	φ12×7.5	1.5	~2	2,048	MIN80(10cm)		MAX70	-20~+60	2	15
	PMX-04B	φ12×7.5	1.5	~2	2,731	MIN85(10cm)		MAX70	-20~+60	2	15
	PMX-04C	φ12×7.5	1.5	~2	2,048	MIN70(10cm)		MAX10	-20~+60	2	15
QFP	QFP-01A	φ14×4.5	1.5	~2	2,670	MIN85(10cm)		MAX70	-20~+60	2	16
	QFP-03A	φ14×4.5	3	~4	2,000	MIN85(10cm)		MAX35	-20~+60	2	16

Washable type (Note2)

Type	Model	Dimensions (mm)	Rated Voltage (V)	Operating Voltage (V)	Resonant Frequency (Hz)	Sound Output (dBA)	Frequency Band(Hz) (MIN80dBA Note3)	Average Current Consumption (mA)	Temperature Range (°C)	Weight (g)	Page
QMX	QMX-05	φ12×9	5	~8	2,400	MIN85(10cm)		MAX40	-40~+85	2	17
	QMX-12	φ12×9	12	~15	2,400	MIN85(10cm)		MAX40	-40~+85	2	17
HGP	HGP-05A	φ16×12	5	~8		MIN85(10cm)	1,700~2,200	MAX70	-40~+90	4	17
	HGP-12A	φ16×12	12	~15		MIN85(10cm)	1,700~2,200	MAX50	-40~+90	4	17
RMX	RMX-06	φ16×14	6	~12	2,048	MIN85(10cm)	2,000~3,000	MAX40	-40~+85	5	18
	RMX-12	φ16×14	12	~18	2,048	MIN85(10cm)	2,000~3,000	MAX40	-40~+85	5	18
QMB-φ16	QMB-01	φ16×14	1.5	~3	2,048	MIN80(10cm)		MAX15	-30~+85	5	18
	QMB-06	φ16×14	6	~12	2,048	MIN85(10cm)		MAX40	-40~+85	5	18
	QMB-12	φ16×14	12	~18	2,048	MIN85(10cm)		MAX40	-40~+85	5	18
SMX	SMX-01	14×18×11	1.5	~2	2,048	MIN80(10cm)	2,000~2,500	MAX40	-30~+80	4	19
	SMX-06	14×18×11	6	~10	2,048	MIN85(10cm)	2,000~2,500	MAX40	-40~+85	4	19
	SMX-12	14×18×11	12	~15	2,048	MIN85(10cm)	2,000~2,500	MAX40	-40~+85	4	19
WMX	WMX-05	φ25×12.5	5	~6	770	MIN85(10cm)		MAX80	-40~+85	10	19
TMX	TMX-06	φ25×12.5	5	~5	730	MIN85(10cm)		MAX80	-40~+85	10	20
	TMX-06S	φ25×12.5	6	~8	1,000	MIN85(10cm)	1,000~1,500	MAX75	-40~+85	10	20
	TMX-12S	φ25×12.5	12	~14	1,000	MIN85(10cm)	1,000~1,500	MAX55	-40~+85	10	20

(Note1 : Please contact us for conditions, These are Non-washable.)

(Note2 : Please refer to page 36.)

(Note3 : MIN87dBA for MMX-01A & MMX-01B, MIN85dB for HGP-05A & HGP-12A.)

Miniature Audio Transducer (Self-contained drive circuitry)

Washable type (Note1)

Type	Model	Dimensions (mm)	Rated Voltage (V)	Operating Voltage (V)	Basic Frequency (Hz)	Sound Output (dBA)	Average Current Consumption (mA)	Temperature Range T(°C)	Weight (g)	Page
TMB	TMB-05	φ12×9.5	5	4~6.5	2,300	MIN85(10cm)	MAX30	-40~+85	2	22
	TMB-12	φ12×9.5	12	8~16	2,300	MIN85(10cm)	MAX30	-40~+85	2	22
HMB	HMB-06	φ16×14	6	4~7	2,200	MIN85(10cm)	MAX30	-40~+85	5	23
	HMB-12	φ16×14	12	8~16	2,200	MIN85(10cm)	MAX30	-40~+85	5	23

Non-washable type

Type	Model	Dimensions (mm)	Rated Voltage (V)	Operating Voltage (V)	Basic Frequency (Hz)	Sound Output (dBA)	Average Current Consumption (mA)	Temperature Range T(°C)	Weight (g)	Page
KMB	KMB-06	20×25×16	6	4~8	2,150	MIN85(10cm)	MAX20	-30~+85	8	24
	KMB-12	20×25×16	12	8~16	2,150	MIN85(10cm)	MAX20	-30~+85	8	24
AMB	AMB-06	20×36×16	6	4~8	2,150	MIN85(10cm)	MAX20	-30~+85	8	25
	AMB-12	20×36×16	12	8~16	2,150	MIN85(10cm)	MAX20	-30~+85	8	25

Low-pitched Sound Buzzer (Non-washable)

Type	Model	Dimensions (mm)	Rated Voltage (V)	Operating Voltage (V)	Resonant Response Time(Hz)	Sound Output (dBA)	Average Current Consumption (mA)	Temperature Range T(°C)	Weight (g)	Page
MMB	MMB-01C	14×18×10.5	1.5	1~2	340	MIN76(10cm)	MAX15	-20~+70	5	28
SMB	SMB-01	16×33×14.5	1.5	1.1~2	200	MIN76(10cm)	MAX15	-20~+60	9	29
	SMB-06	16×33×14.5	6	3~7	330	MIN76(10cm)	MAX23	-40~+80	9	29
	SMB-12	16×33×14.5	12	7~17	330	MIN76(10cm)	MAX15	-40~+80	9	29
	SMB-24	16×33×14.5	24	18~30	330	MIN76(10cm)	MAX14	-40~+80	9	29
CMB	CMB-06	16×22.5×14.6	6	3~8	150	MIN76(10cm)	MAX23	-40~+85	8	30
	CMB-12	16×22.5×14.6	12	8~16	150	MIN76(10cm)	MAX15	-40~+85	8	30
	CMB-24	16×22.5×14.6	24	18~30	150	MIN76(10cm)	MAX14	-40~+85	8	30
YMB	YMB-06	26×26×19.7	6	4~8	400	MIN75(100cm)	MAX35	-40~+70	14	31
	YMB-12	26×26×19.7	12	8~16	400	MIN75(100cm)	MAX25	-40~+70	14	31
	YMB-24	26×26×19.7	24	20~28	400	MIN75(100cm)	MAX25	-40~+70	14	31
PMB	PMB-06	26×40×19.5	6	4~8	400	MIN75(100cm)	MAX35	-40~+70	14	32
	PMB-12	26×40×19.5	12	8~16	400	MIN75(100cm)	MAX23	-40~+70	14	32
	PMB-24	26×40×19.5	24	20~28	400	MIN75(100cm)	MAX21	-40~+70	14	32
RMB	RMB-06	φ26.4×41×17.6	6	4~8	400	MIN75(100cm)	MAX33	-40~+70	18	33
	RMB-12	φ26.4×41×17.6	12	7~16	400	MIN75(100cm)	MAX23	-40~+70	18	33
	RMB-24	φ26.4×41×17.6	24	20~28	400	MIN75(100cm)	MAX21	-40~+70	18	33
IMB	IMB-06	φ26.4×41×28.6	6	4~8	400	MIN75(100cm)	MAX33	-40~+70	23	34
	IMB-12	φ26.4×41×28.6	12	7~16	400	MIN75(100cm)	MAX23	-40~+70	23	34
	IMB-24	φ26.4×41×28.6	24	20~28	400	MIN75(100cm)	MAX23	-40~+70	23	34

(Note : Please refer to page 36)

MINIATURE AUDIO TRANSDUCERS (EXTERNAL DRIVE CIRCUITRY)

Star Micronics line of miniature audio transducers offer the highest quality and reliability at a cost effective price. Star's extensive line of transducers include devices that are sealed for wave and wash processes, have side sound ports, and include a variety of different sizes to help meet all your design parameters.

OPERATION PRINCIPLES AND CONSTRUCTION

Figure 1 shows the construction of the QMX transducer, one of Star's initial miniature designs. The operating principle of these miniature electromagnetic transducers is explained as follows:
 The coil (9) is located in the magnetic circuit consisting of a permanent magnet (6), an iron core (5), a highly permeable metal disk (4), and a vibrating diaphragm (3).
 The disk and diaphragm are attracted to the core by the magnet's magnetic field. When an oscillating signal is applied to the coil, the diaphragm will oscillate relative to the frequency of the signal.

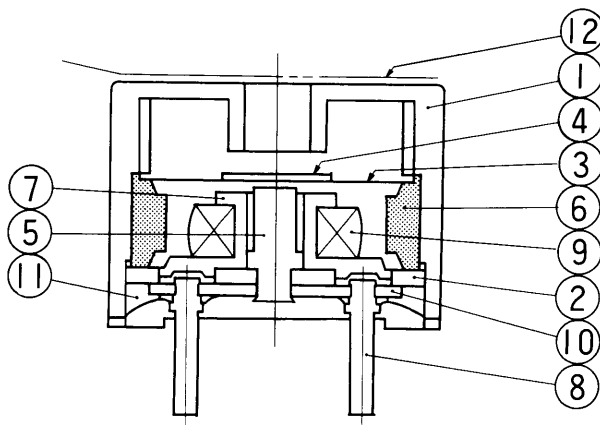

No.	Part Name
1	Housing
2	Base
3	Diaphragm
4	Magnet piece
5	Core
6	Plastic magnet
7	Bobbin
8	Pin
9	Coil
10	P.C Board
11	Potting material
12	Masking label

Fig.1 Construction view of type QMX

APPLICATIONS

Printer, telephone, timer, pager, cellular phone, electronic oven, electronic cash register, POS system, electronic typewriter, computer terminals, keyboard, copy machine, safety equipment for motor vehicles, portable and battery operated equipment.

★Note: All the transducers in this catalog require external circuitry to provide the drive signal to the transducer.

■ Frequency response

As explained in the section discussing the operating principles, our transducers are designed to produce sound according to the frequency of the drive signal applied.

The frequency response data given for each transducer is a measure of the effectiveness with which the transducer reproduces the different frequencies applied.

Frequency response varies from type to type, it is therefore essential to select an appropriate transducer which will meet the specific requirements of the application.

All frequency response data given is measured with a square wave voltage signal operating from zero to peak (V_{o-p}), it should be noted that our transducers may not produce the same frequency response as specified if they are driven with a sine wave or any other wave form.

■ Signal input polarity

If the voltage signal input V_{o-p} is applied to our transducer with the polarity reversed, a sound will be generated but it will not always meet the catalog specifications for the sound pressure level.

This is because the reversed polarity input changes the magnetic force direction from "attract" to "repulse" or vice versa, which can cause the resonant frequency to deviate from its original point and produce variations in the sound pressure level.

However, if the voltage signal input alternates from positive peak to negative peak (V_{p-p}), the reversed polarity will have no effect on the sound produced.

■ How frequency response characteristics are affected by changing the input of the amplitude.

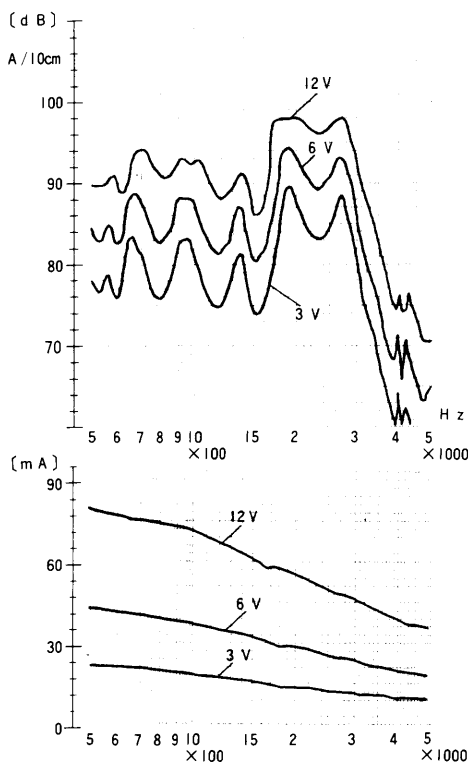

Some design engineers do not drive audio transducers at the rated voltage recommended by the manufacturer.

In most cases this is due to the voltage available relative to the customer's specific application. Star's catalogues and data sheets show the frequency characteristics with respect to the rated voltage. When different voltage amplitudes are applied to a given transducer, the frequency characteristics change.

Generally, as the input voltage amplitude decreases below the rated voltage, the resonant frequency (f_0) rises.

Conversely as the input voltage increases above the rated voltage, the resonant frequency (f_0) falls.

The basic resonant frequency of a specific transducer is a fixed value relative to its acoustic design. As a result, at lower than rated voltage the frequency response band tends to narrow, and at higher voltage values the frequency band tends to be wider.

Consequently if the input voltage is too low, shifting the resonant frequency higher, the original rated frequency (i.e. 2,048Hz) may not fall within the frequency band. Thus the sound output will be well below the rated SPL.

Type RMX-06

applied voltage: 3V, 6V, 12V, 1/2 duty, square wave

Distance for measurement: 10cm

■ Mean current consumption 1

The mean current consumption designated as Max. OO(mA) in the specifications represents the maximum value of the mean current that will flow when the rated voltage is applied with no limitation to current supply.

It is not the maximum allowable current that may be applied to the device, in practice the peak may be 2 or 3 times the mean current. It is therefore essential to ensure the supply circuit is capable of providing sufficient current, otherwise the sound pressure level may not reach the specified output, or no sound at all may be produced due to an oscillation failure.

Example: QMB11PN. Mean current is specified as Max. 10mA.

The supply circuit should be designed to supply not less than 30mA.

■ HELMHOLTZ RESONATOR TO INCREASE SOUND PRESSURE

The sound producing devices like our sound transducers are generally used in certain enclosure to have an appropriate resonance chamber in front of the sound producing device, it is possible to meet the requirements to a certain extent, for instance, to obtain an increased sound pressure, improved response in wider range of frequencies, or softened sound output. Design such resonator called "Helmholtz Resonator" according to the following equation :

$$f_v = \frac{cD}{4} \sqrt{\frac{1}{\pi V (L + 0.75D)}}$$

Where

f_v : resonant frequency of resonator [Hz]
 V : volume of resonance chamber [mm³]
 D : diameter of sound emission hole [mm]
 L : depth of sound emission hole [mm]
 c : speed of sound = approx. 344000 [mm/sec]

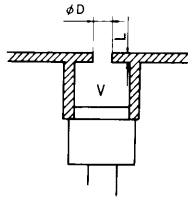

Designing the resonator to have such dimensions that the resonant frequency (f_v) of the resonance chamber may be greater than the resonant frequency (f_0) of the sound producing device, improves the frequency response in wider frequency range, increases the sound pressure and softens the sound output eliminating the harmonic components. (These effects may not be obtained if f_v is lower than f_0 , or reduced if f_v is excessively higher than f_0 . For increasing the sound pressure only, it is recommended to set the f_v two times as high as f_0 .)

The above equation is a theoretical formula and actually it is needed to give a slight adjustment about the space inside the sound producing device itself.

It is recommended to adjust the diameter of the sound emission hole to find the optimum diameter based on the value predetermined in the equation mentioned above.

Following example shows one of the typical design works of the resonator.

For an actual design, however, it is needed to adjust the parameters theoretically determined from the equation (1) because the resonator inside the transducer could not be ignored.

Generally an additional resonator is designed by adjusting some parameters such as sound hole diameter with the transducer actually mounted to the product to which it is intended to be incorporated.

With the resonator design examples using QMB-105P whose fundamental frequency is 2048 Hz, we would like to indicate how the transducer characteristics are affected by an additional resonator provided.

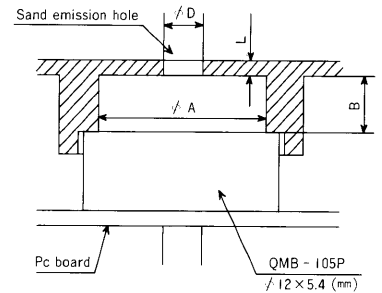

Fig.2

[Geometrical conditions (see Fig.2)]

$\phi A = 10\text{mm}$
 $L = 1.1\text{mm}$
 $B = 5\text{mm}$

I . To allow to respond to wider range of frequency input

[Design]

To broaden the frequency range to 2048 ~ 2700 Hz, the resonator geometry is determined with an aim that the f_v should be around 2700 Hz, slightly higher than the fundamental frequency of the transducer.

The sound hole diameter ϕD is set to 1.5 mm. With those parameters set, the f_v may be calculated as 2460 Hz from the equation (1).

[Actual measurement]

Frequency response... as shown in Fig 4

f_v 2700 Hz

As shown in Fig 4, the frequency range may be broadened and a softer sound may be produced with the harmonic components considerably eliminated.

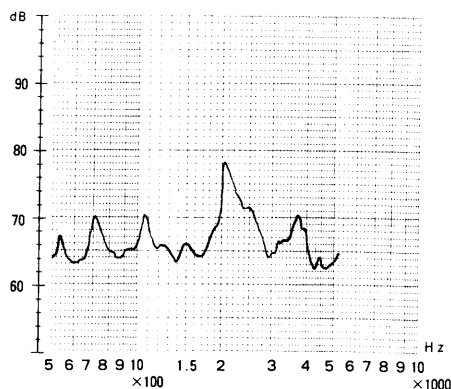

Fig.3 Frequency response without additional resonator

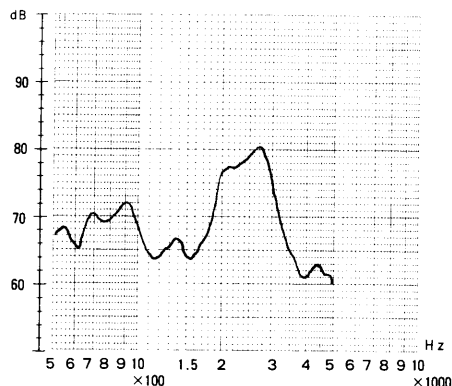

Fig.4 Frequency response with resonator (Design I)

II . To increase the SPL

[Design]

To increase the SPL at the fundamental frequency of 2048 Hz, the resonator geometry is determined with an aim that the f_v should be around 4100 Hz, almost twice as high as the fundamental frequency of the transducer.

The sound hole diameter ϕD is set to 3.3 mm. With those parameters set, the f_v may be calculated as 4000 Hz from the equation (1).

[Actual measurement]

Frequency response... as shown in Fig 5

f_v 4000 Hz

As shown in Fig 5, the SPL may be considerably increased, while the sound may become sharper due to its secondary harmonic components increased.

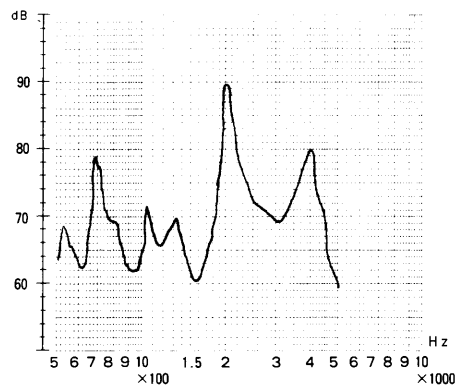
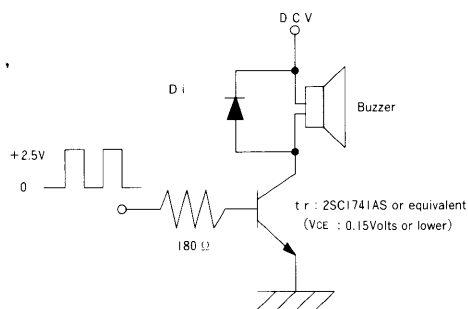

Fig.5 Frequency response with resonator (Design II)

These are just a few examples of additional resonators, for which an infinitude of geometry may be designed. Although it seems to have no problem when calculated on the desk, an excessively small diameter of a sound hole will increase an acoustic resistance and may result in no improvement. If no sufficient volume could be secured for a resonator, it is recommended to have a sound hole diameter equal to or greater than that of the sounder to utilize its capability as much as possible. Please contact us (Buzzer Sales Section) for design of resonator.

■ Measuring Circuit

Our standard circuit for measurement is as shown below:
($V_{CE} = 0.15$ volts or lower)



■ RATED VOLTAGE

The term "Rated Voltage" in the specification of Star's Transducers and Buzzers are described as:

◆ For Miniature Audio Transducers (External Drive Circuitry)

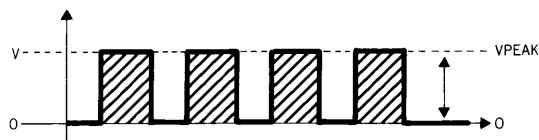

e.g.
MMX-01C: Rated Voltage is "1.5V".

$$1.5V = 1.5V_{o-p}$$

◆ For Miniature Audio Transducers and Low Pitched Sound Buzzers (Self-Contained Drive Circuitry)



e.g.
HMB-06 and YMB-06 is continuous "6V".

$$6.0V = 6.0DCV$$

(continuous)

■ Recommended reflow oven temperature profile for reflowable transducers

Reference standard: EIAJ ED-4702
Infrared reflow oven

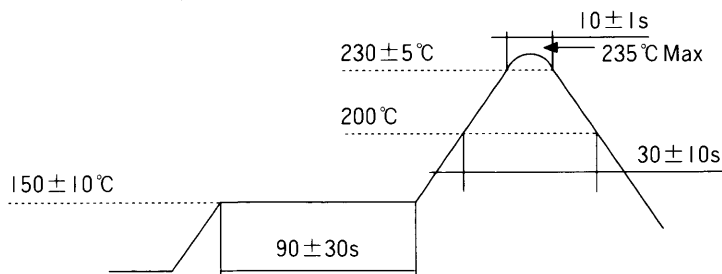

If you have any questions about the above temperature profile for infrared reflow oven, please feel free to contact us.